

# Mechanical Clamping Tools

## Quick-Change Systems

### Mechanical Quick-Change System

#### Quick and easy tool change

The mechanical quick-change clamping system of König-mtm provides an extremely fast and very easy change of the clamping device and a high degree of processing precision.

This results in a reduction of set-up efforts and set-up time as well as a prevention of possible assembly errors. Therefore, the efficiency of the production line can be significantly increased.

The integrated permanent clamping system enables secure clamping even in the event of a machine malfunction.

#### Special suitability for vertical hobbing machines

The mechanical quick-change clamping system was designed for the special use on vertical machine tools in connection with mechanical clamping devices made by König-mtm.

It can be used on all common hobbing machines due to the extremely flexible design. The machines need a pressure/pull rod with two functions.

- Ease of handling (no bolting-on)
- High workpiece flexibility
- Improved productivity
- High radial and axial run-out precision
- Robust construction
- High pull-down force
- Short tooling effort/time
- Especially suitable for mechanical clamping devices

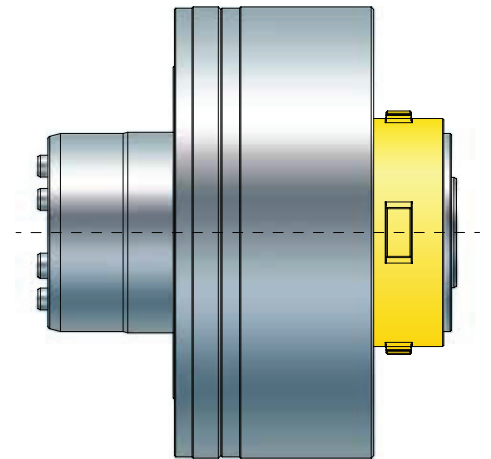

# Mechanical Clamping Tools

## Quick-Change Systems

### Zero-point quick-change chucks

König-mtm is presenting clamping tools with zero-point quick-change system. High-precision quick-change chucks based on the zero-point pallet system are combined with Königdorn® clamping tools (hydraulic or mechanical mandrels or chucks).

Zero-point clamping systems facilitate extremely fast and simple tool change with maximum precision.

The newly developed, extremely sturdy and deflection-resistant joint between the clamping tool and pallet achieves outstanding repeat accuracy in both radial and axial run-out and is thus ideally suited for a wide range of machining processes, e.g. turning and hobbing through to high-precision gear grinding.

The zero-point quick-change chuck is permanent clamped (pneumatic unclamping automatically via machine tool or manually via blow gun).

The Königdorn® clamping tools are operated via the machine tool's hydraulics (by push-rod or oil pressure).

- Ease of handling (no bolting-on)
- High workpiece flexibility
- Improved productivity
- Maximum radial and axial run-out precision (repeat accuracy  $\leq 3 \mu\text{m}$ )
- Amenable to automation
- Minimal tooling effort/time
- Suitable for all clamping devices

